



**SAAB**

# Saab experience with application of composites in aerospace structures



**Pontus Nordin, Saab Aeronautics**

**2011-09-05**

**ICAS Biennial workshop 2011, Stockholm**

# Advanced Materials and Manufacturing - Certification and Operational Challenges

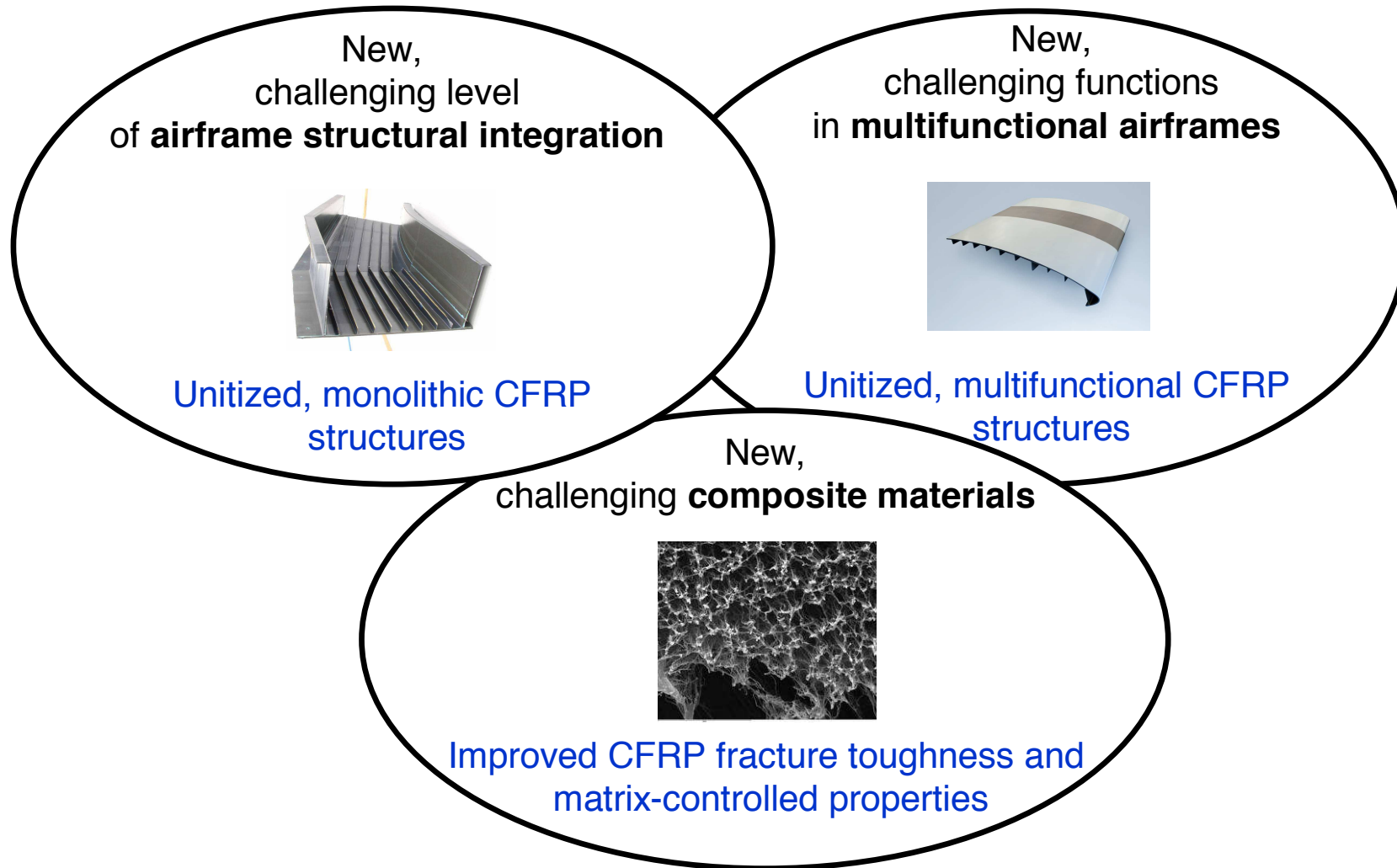

# 40+ years of Saab CFRP airframe applications



# First Saab flying CFRP aircraft component, 1971 Saab 105 rudder trim tab



First generation CFRP  
Adhesive bonding

# **Saab composite airframe applications**

*A short review of selected hardware*

# Saab 2000 Composites and Adhesive Bonding

	Glass Fiber Composite (GFRP)	Sandwich
	Glass Fiber Composite (GFRP)	Mono shell
	Carbon Fiber Composite (CFRP)	Sandwich
	Carbon Fiber Composite (CFRP)	Mono shell
	Aramid Fiber Composite (AFRP)	Sandwich

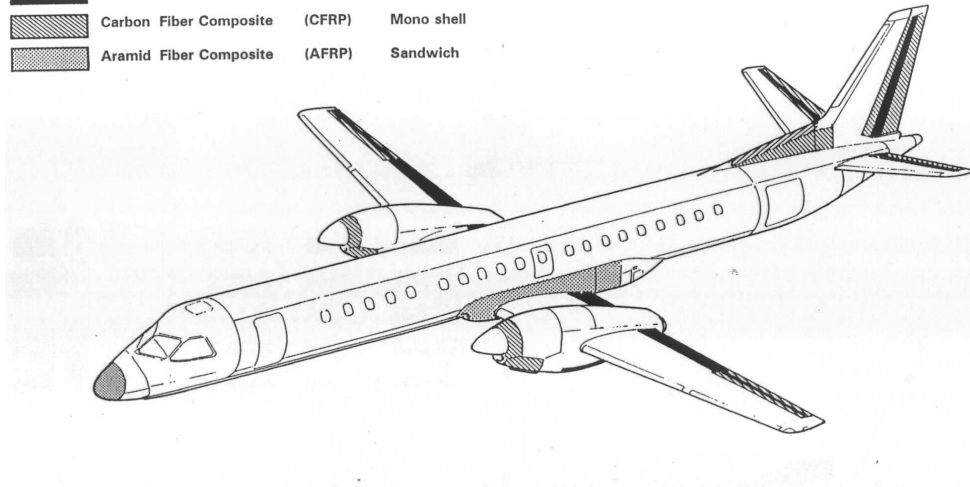

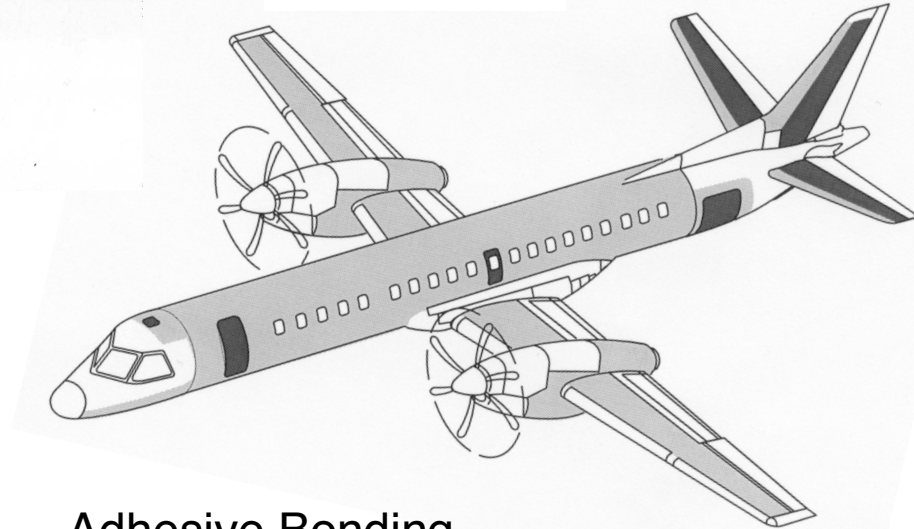

**Composites**  
7 % b.w.



**Adhesive Bonding**  
Extensive use

# Saab Gripen Composites

-  Carbon-Fiber Composite (CFRP)
-  Glass-Fiber Composite (GFRP)
-  Aramid-Fiber Composite (AFRP)



Gripen NG with new applications



39 387h 970902



# Saab development of Neuron centre fuselage, including large composite applications





# Commercial Aeronautics - AIRBUS

Development and manufacture of CFRP airframe units



Ailerons  
A320 family



Pylons, rear structure  
A340-500/600



Main landing gear doors  
A340-500/600



# Commercial Aeronautics - BOEING

Development and manufacture of advanced composite and metallic parts for the B787-8 and B787-9 including:

- ▶ Large cargo doors
- ▶ Bulk cargo doors
- ▶ Access doors



# **Saab experience with composite applications**

*Avoiding the 99 % level*

# The Saab CFRP track record

- ▶ 43 years of CFRP technology with no **operational set-backs**
- ▶ Priority on **prepreg** technology (tape) and **monolithic structures**
- ▶ Early military CFRP applications (Viggen fighter) followed by extensive use on Saab Gripen. **Continuous and thorough development** of materials & processing technology since day 1
- ▶ Early use of AFRP and CFRP on Saab commuters 340 & 2000 in combination with extensive use of **adhesive bonding** on both aircraft. Both technologies use autoclave processing with high manufacturing quality. No single in-service incident for Saab 340 & 2000 due to bonding
- ▶ Early supply of aerostructures to BAe and McDonnell Douglas, followed by development and manufacture of CFRP structures for Airbus and Boeing, incl. **high build-rate unitized parts**
- ▶ **Early use of modeling and simulation**, in structural and multi-disciplinary optimization
- ▶ Saab organization, company size, co-location of airframe development disciplines and a strong company focus on R&D (corresponding to ~ 20 % of sales over many years) have been key contributors to our CFRP technology track record

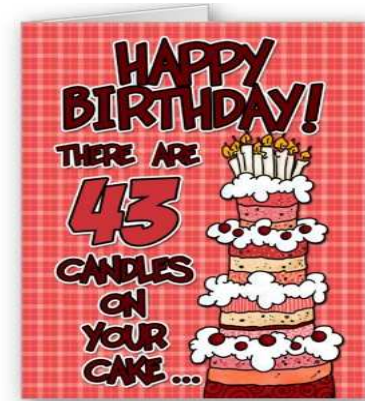



# Structural integration for cost and weight efficiency must be based on sound designs and robust manufacturing processes

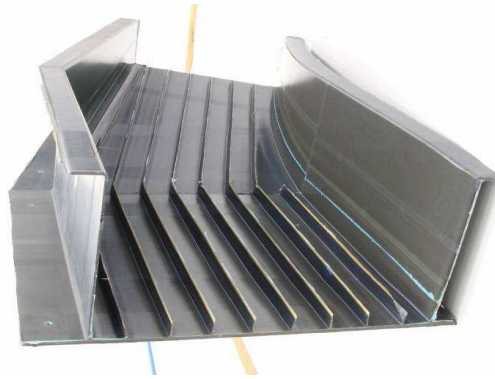

Structural integration (co-cured unitized parts) is a major advantage when using CFRP and other composites, allowing both improved cost and weight efficiency, but consequences of design oversights or processing deviations are more severe than for conventional structures

- ▶ Full control of **all** design and manufacturing parameters, “**99 % right can be 100 % wrong**”
- ▶ Saab approach to unitized parts is based on monolithic applications of CFRP prepreg materials, automated tape laying and autoclave curing
- ▶ Out-of-autoclave processing has not yet shown sufficient robustness
- ▶ Heat-forming of prepreg in stacks optimized for forming, has been key to robust processing
- ▶ Strong emphasis on structural and multidisciplinary optimization

# Saab unitized CFRP parts, example

This commercial CFRP airframe component was developed by Saab in order to reduce cost and weight while improving manufacturability.

Fully co-cured, prepreg-based, monolithic laminate design.

Structural analysis, multidisciplinary optimization, automated manufacturing operations, innovative but robust tooling technology and engineered forming of prepreg were key contributors to the realization of this component

Current production:	36 ac/month
Plan for 2012:	42 ac/month

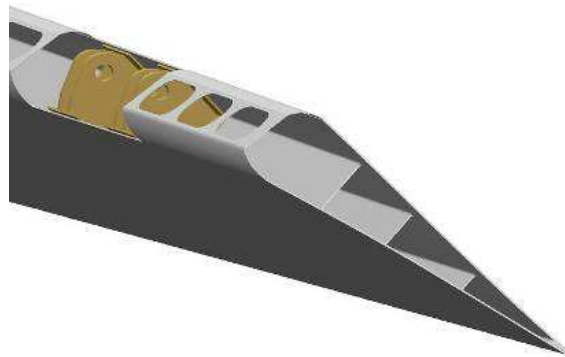

# Toughening strategies for damage resistant CFRP

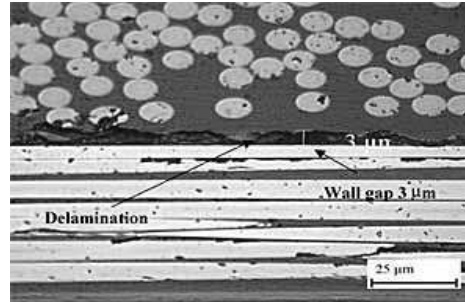

- ▶ First generation epoxy matrix systems were not modified for toughness (brittle), but were used successfully in “black metal” designs with limited or no structural integration
  
- ▶ Strategies for improved toughness CFRP materials have included:
  - **thermoplastic matrix systems** instead of thermoset materials
  - **thermoplastic particles** or other additions in thermoset matrix systems
  - **resin-rich layers** between prepreg plies with higher fiber content
  - **hybrid CFRP materials** using aramid, polyethylene or other “ductile” fibers
  
- ▶ All methods improve toughness but may reduce matrix-controlled mechanical properties such as compression -, interlaminar- and bolt bearing strength. Some toughened composites limit the airframe structural efficiency, due to a low fiber volume (< 60 %)

# The mother of (nearly) all CFRP design oversights?

- ▶ Dissimilar thermal expansion in combination with anisotropic processing- and mechanical properties is probably the most common reason for costly CFRP design oversights

- Processing: Resin flow and cure shrinkage
  - Mechanical: Weak matrix phase with limited fracture toughness and strain to failure

- ▶ Direct, indirect and not obvious influence on manufacturability and use of CFRP structures

▶ Typical CTE	Carbon fibers (in fiber direction):	$-0,8 * 10^{-6} / ^\circ K$
	Cured epoxy resin	$55 * 10^{-6} / ^\circ K$
	Aluminum	$23 * 10^{-6} / ^\circ K$
	Titanium	$8 * 10^{-6} / ^\circ K$
	Invar36	$1,6 * 10^{-6} / ^\circ K$

- ▶ Similar effects from CFRP volume and shape changes due to matrix moisture and cure shrinkage
- ▶ Modeling and simulation can identify critical design cases, but the task is challenging and must include manufacturing operations and effects due to processing of CFRP
- ▶ Saab focus on modeling and simulation of CFRP includes manufacturing processes, e.g. prepreg drape (fiber angle analysis), curing tool-part interaction, laminate spring-back effects and cured shape analysis



# **Opportunities with CFRP addressed in current R&D**

*Multifunctional applications, unitization and  
improved material properties*

# Saab current development of composite technologies

- Saab focus areas for composite R&D include:
  - Multifunctional CFRP structures, incl. new functions such as natural laminar flow (NLF)
  - Unitized CFRP structures
  - Improved CFRP fracture toughness and matrix-controlled mechanical properties

- Two representative development projects discussed today:

## **Multifunctional unitized structures**

EU JTI Clean Sky, Smart Fixed Wing Aircraft

- Saab development of laminar flow composite structures

## **Improved CFRP damage resistance**

Nano-engineered Composite Aerospace Structures (NECST)

- Saab development of nano-engineered CFRP materials and manufacturing methods



# Smart Fixed Wing Aircraft (SFWA)

## Integrated Technology Demonstrator *at a glance*

### Objectives

- Reduce the aircraft drag by 10% by reducing the wing drag by 25% using laminarity, and by reducing the aircraft weight and drag through innovative control surfaces and load control.
- Reduce the fuel burn of aircraft by 20% integrating advanced engines, in particular the Counter Rotating Open Rotor (CROR).
- Reduce the aircraft noise by up to 10 db by engine noise shielding configurations, in particular for business jets.
- The key role to implement these technologies and to achieve the objectives in the SFWA-ITD is through the validation in large scale demonstration in real flight condition.

# BLADE

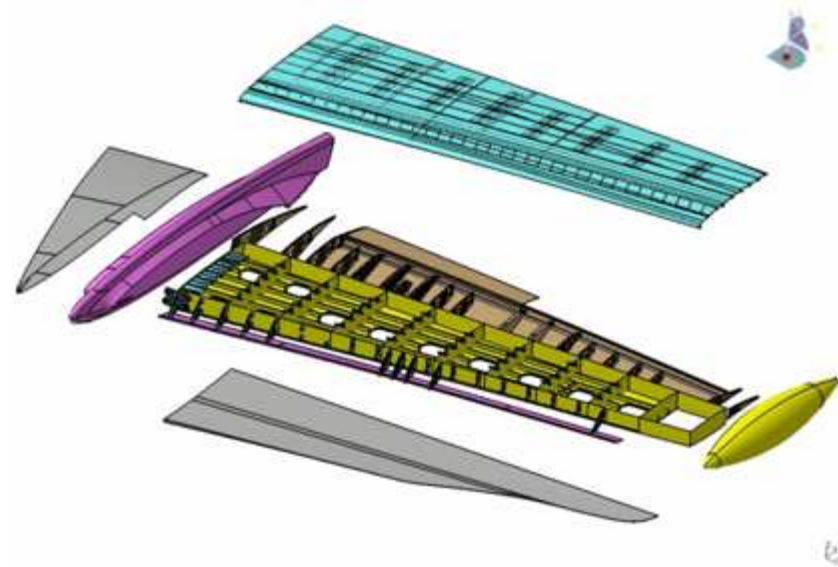

## The players

Coordination: Airbus, SAAB AB

Other members: Dassault, SAFRAN, Fraunhofer, EADS-CASA, Rolls-Royce, Thales, DLR, ONERA, INCAS-cluster, "NL-Cluster", Qinetiq, RUAG, Aernnova



# Saab status of design and build the “HSDP” Smart Wing demonstrator

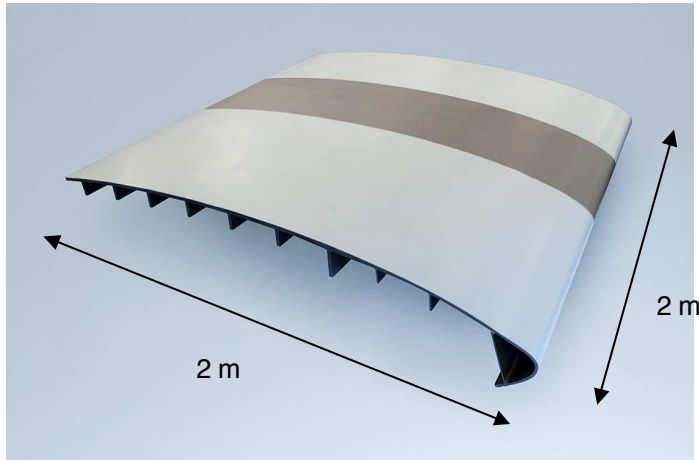

## Complexity

Combination of several advanced design principles in a fully integrated co-cured solution

Very challenging requirements, including surface quality and shape

## Test Panel

- Evaluation of design concepts
- Tooling technology
- Surface characterization

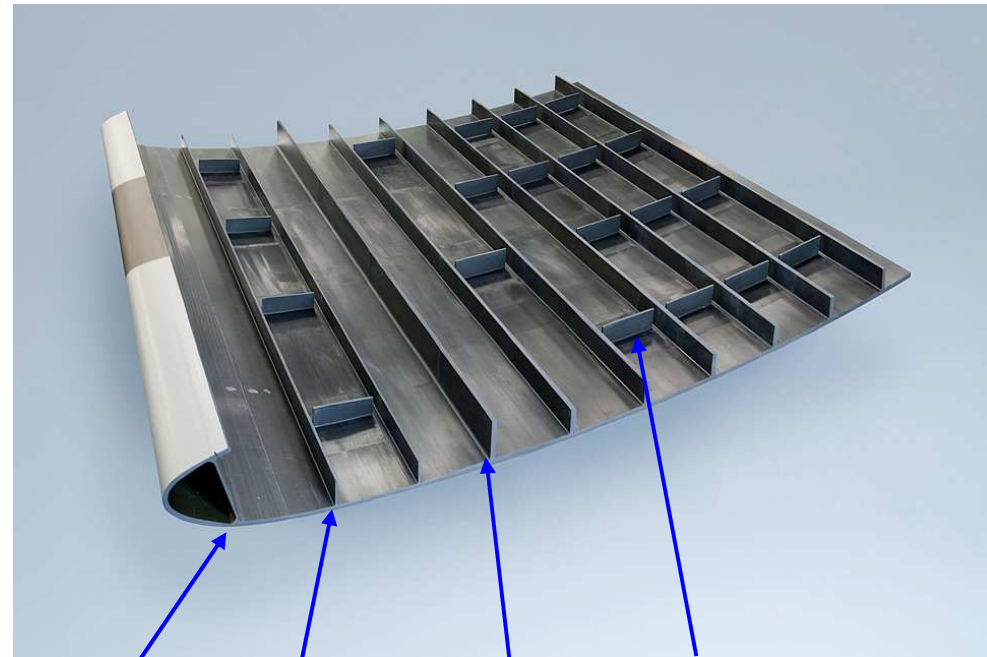

Sub spar

Stringer

Spar Cap

Rib feet

# Multifunctional CFRP structures under development by Saab

## Laminar flow aerostructures with improved functionality

- ▶ Improved de-icing/anti-icing, highly efficient
- ▶ Lightning strike protection
- ▶ Erosion resistance
- ▶ Damage resistance
- ▶ Improved manufacturability
- ▶ Improved structural efficiency
- ▶ Improved affordability
- ▶ Inspectability, serviceability, replacability, reparability



# Graphene-based nanomaterials for improved CFRP fracture toughness

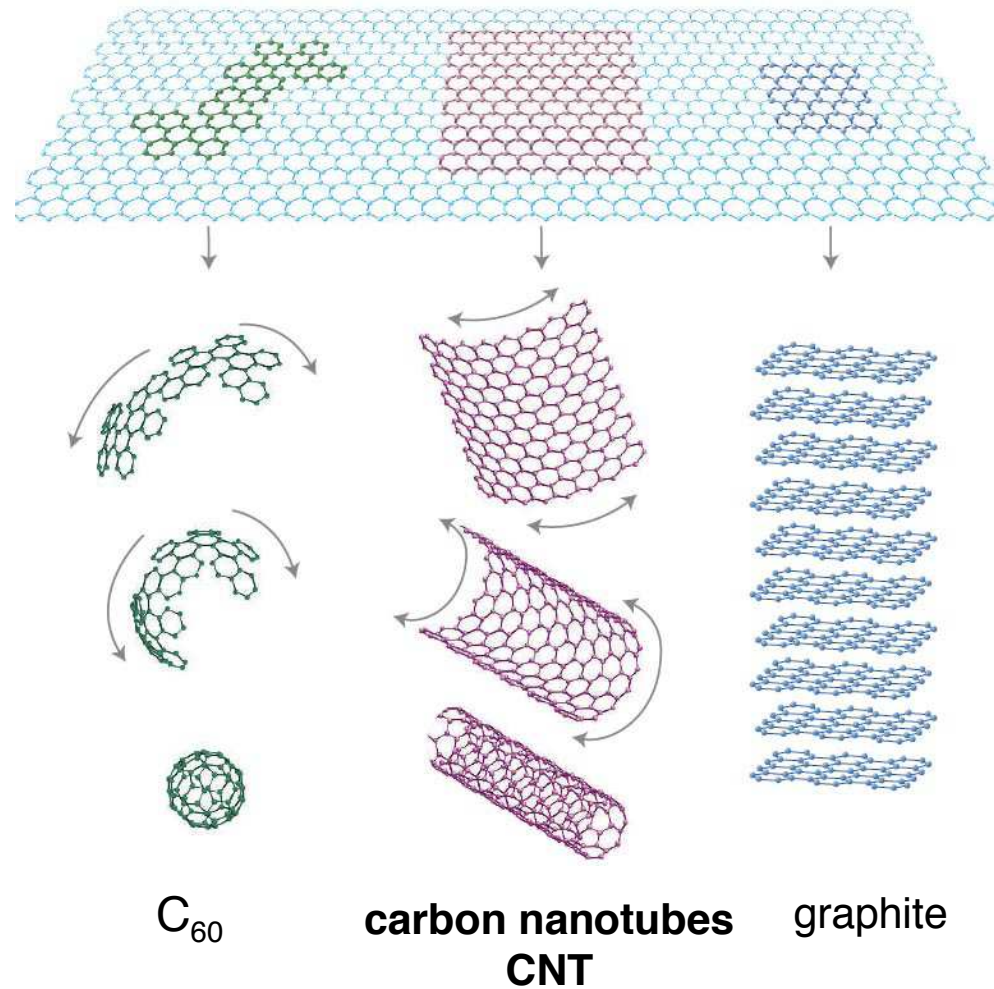

# Local and Global NECST Collaborations

## Global **Industrial** and **Academic** Collaborations

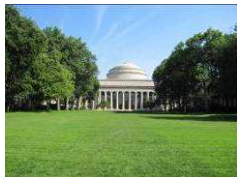
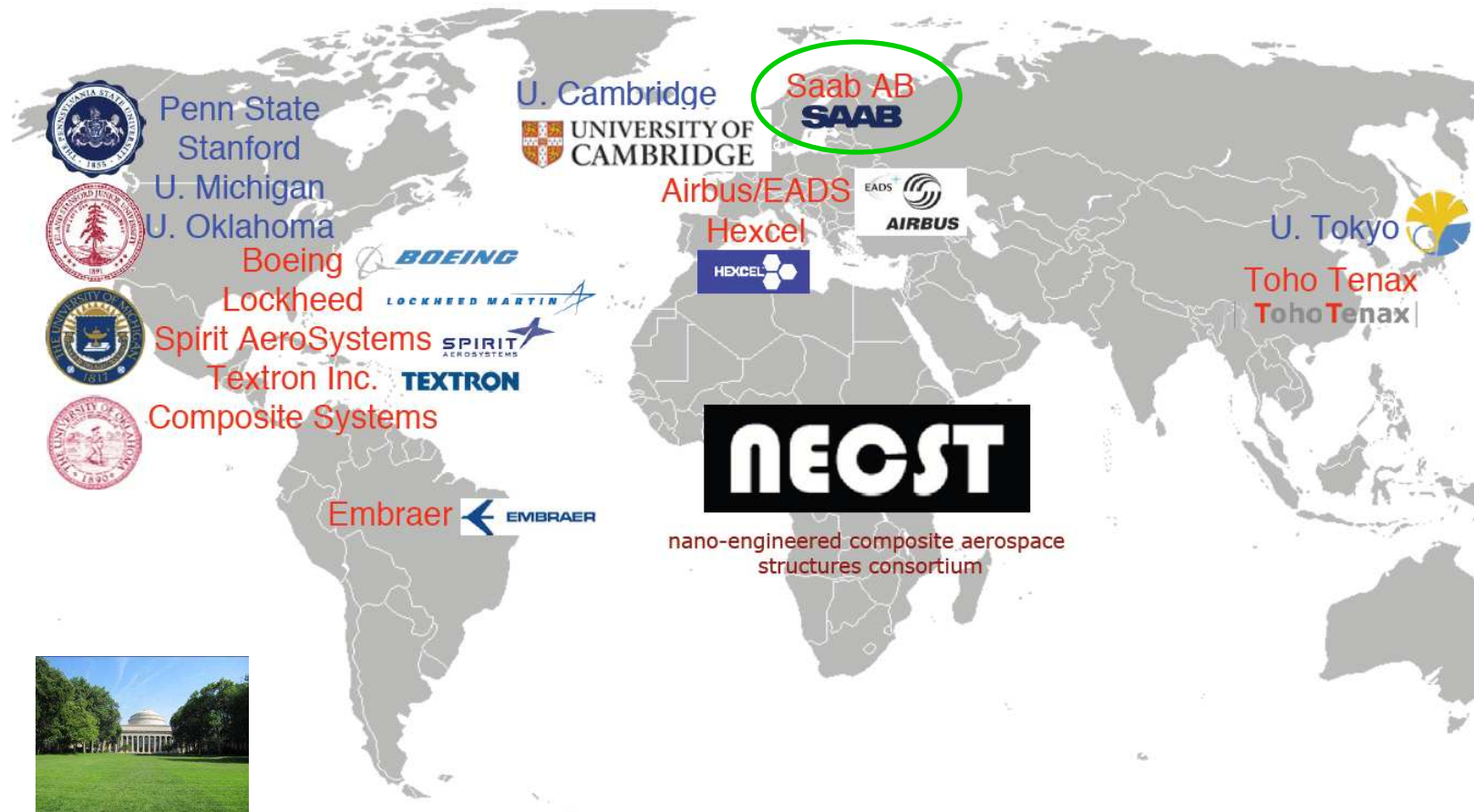

**MIT** : Consortium leader



# Nanostitching of CFRP laminates

- One of several technologies under development
- Other technologies include
  - CNT dispersed in CFRP epoxy matrix (Saab)
  - "Fuzzy fibers", CNT grown on fibers (NECST)
- Good progress on nanostitched laminates
  - Mode 1 and mode 2 fracture toughness
  - Matrix-controlled mechanical properties
- Nanostitching, as applied in tested Saab CFRP laminates, can suppress delamination and damage growth in mechanically loaded structures
- Several challenges to be addressed over the next years
  - upscaling of the manufacturing processes (ongoing)
  - application in secondary airframe structures
  - application in primary airframe structures
  - certification

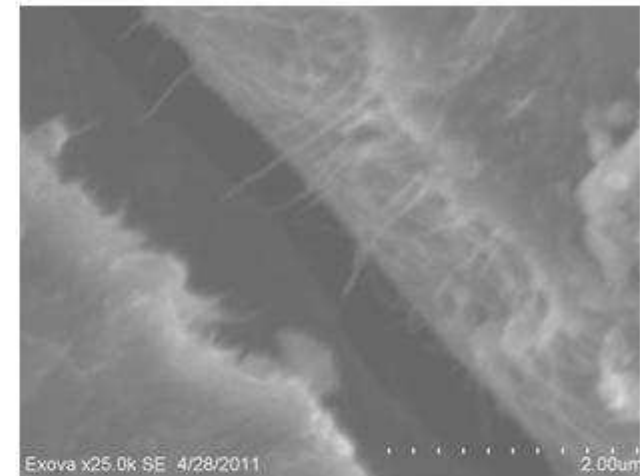
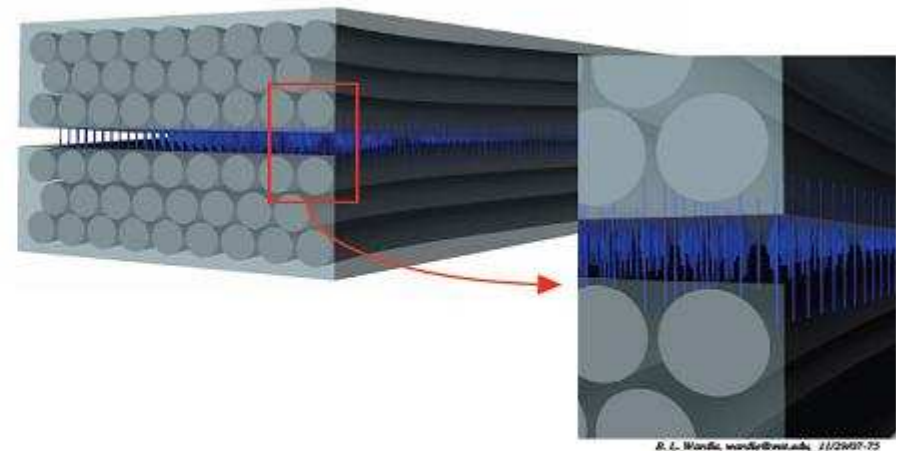

SEM picture: Lisa Emkqvist, Exova

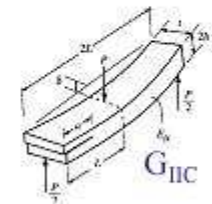
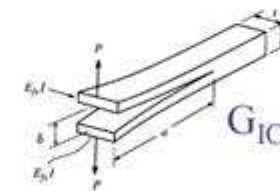

# Conclusions and Summary

## *Challenges and rewards*

# Saab Summary - Certification and Operational challenges

- ▶ Composite designs based on current generation toughened prepreg materials are mainly driven by limitations in CFRP fracture toughness, matrix-controlled mechanical properties and manufacturing issues related to anisotropy
- ▶ Future multi-functional airframes, based on NLF aerodynamics and other advanced concepts, will use extensive structural integration and new technologies. Such airframes will be significantly more challenging to develop and certify than current CFRP structures. Their realization will require materials, designs and manufacturing methods, including new NDI, to ensure the necessary improved quality, damage tolerance and durability.
- ▶ Emerging technologies for nano-engineered inter- and intralaminar strength improvements and toughening, based on CNT and other efficient materials, have demonstrated significant progress
- ▶ Development and certification of nano-engineered CFRP unitized structures (and/or alternative technologies) will be challenging, but potential operational improvements include both cost and weight efficiency as well as improved durability and related effects
- ▶ The ongoing development of CFRP structural technologies calls for a corresponding improvement of relevant analysis methods



**SAAB**

**SAAB**GROUP.COM